

PART NO. "P"=3.5 MAX [.138]	"H"	HOLE SIZE	"T"	INSIDE DIAMETER "ID"	OUTSIDE DIAMETER "OD"	MATERIAL
**QFG-1	18±0.25 [.709]	18.5-20 [.728-.787]	11.4 [.449]	13±0.25 [.512]	24.5±0.25 [.965]	SILICONE RUBBER SHORE 55 A, (RMS-368)
**QFG-2	24±0.25 [.945]	25-26 [.984-1.024]	10.4 [.409]	18±0.25 [.709]	29.5±0.25 [1.16]	

PART NO. "T"=.315 [8] "P"=.06 [1.5]	PART NO. "T"=.375 [9.5] "P"=.12 [3]	HOLE SIZE "H"	INSIDE DIAMETER "ID"	OUTSIDE DIAMETER "OD"
*QFG-16200	*QFG-16220	.39 [10]	.24 [6]	.53 [13.5]
*QFG-16201	---	.43 [11]	.28 [7]	.57 [14.5]
---	*QFG-16222	.47 [12]	.32 [8]	.61 [15.5]
*QFG-16203	QFG-16223	.55 [14]	.39 [10]	.69 [17.5]
*QFG-16204	*QFG-16224	.63 [16]	.47 [12]	.77 [19.5]
QFG-16205	---	.71 [18]	.55 [14]	.85 [21.5]
*QFG-16207	---	.87 [22]	.71 [18]	1.00 [25.4]
---	*QFG-16228	1.02 [26]	.87 [22]	1.16 [29.5]
QFG-16209	QFG-16229	1.10 [28]	.94 [24]	1.24 [31.5]

*SEE NOTE 2.

**PART DESIGNED IN METRIC, IMPERIAL DIMENSIONS FOR REFERENCE ONLY.

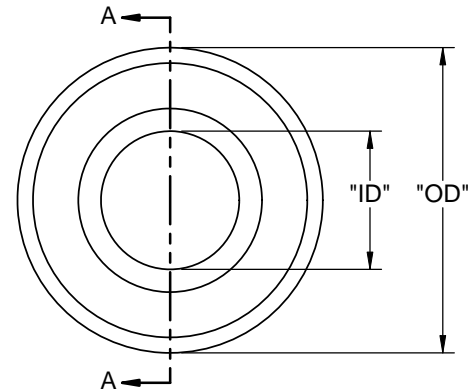
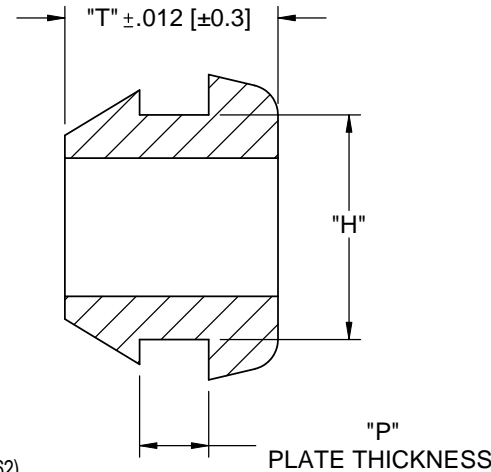

NOTES:
 1. MATERIAL: PVC (RMS-25)
 COLOR: BLACK.
 *2. MATERIAL: THERMOPLASTIC ELASTOMER UL 94 HB (RMS-262)
 COLOR: BLACK.
 -THERMOPLASTIC ELASTOMER UL 94 HB (RMS-374), COLOR WHITE.
 AVAILABLE BY SPECIAL ORDER ONLY.
 TO ORDER ADD SUFFIX "WH" TO THE PART NO.

SECTION A-A
 SCALE 3 : 1

J	SEE CO 200249 FOR CHANGES	SK	09/25/08
I	SEE CO 200241 FOR CHANGES	SK	09/16/08
H	SEE CO 200149 FOR CHANGES	SK	04/10/08
G	SEE CO 200109 FOR CHANGES	SK	01/18/08
F	SEE CO 200041 FOR CHANGES	SK	09/28/07
E	SEE CO 200017 FOR CHANGES	SK	09/17/07
D	COMPLETELY REDRAWN, SEE ECN #1074	SK	10/11/06
-	SEE ENGINEERING FOR REV A-C	---	---
REV.	DESCRIPTION	ENGR.	DATE

TITLE: QUICK-FIT GROMMET				DWG IN IN [MM]		FINAL	
CREATED USING SOLIDWORKS	FILE #: QFG	DWN: SK	APP: RT	PART #		PRINT TYPE	
TOLERANCES UNLESS NOTED .XX=±.010 .XXX=±.005 FRAC.=±1/64 ANG.=±1°	SHEET: 1 OF 1	SHEET SIZE: A	DT: 10/11/05				
RE: RICHCO, INC.		RICHCO, INC. ENG@RICHCO-INC.COM (773) 539-4060		SEE TABLE		CA	